

Dear Sir / Madam

Thank you for your interest in the Australian designed and manufactured hydraulic crane, the “**Lindsell Hoist™**.” The cranes are designed to fit any vehicle fitted with a tray or level surface. Easy packaging enables the owner to fit at their workplace. The cranes simply bolt to any corner of the tray. Your payload capacity is virtually unchanged as the standard unit weighs only 88kg and up to 150 kg for the JRT Full Hydraulic model. The base of the hoist is folded to ensure light weight, strength and only 50 mm wide. Stock crates, toolboxes and the like can remain on the vehicle. Generally the crane is used to lift items that require two or more people, eg Generator, compressors, welders, 44 gallon drums and fencing materials. The Lindsell Hoist does not require a license to operate and is complete with operating and safety instructions.

The Lindsell Hoist is powered by a 12 or 24 volt electric/hydraulic power pack which uses the vehicle’s battery. This independent power unit enables the telescopic boom to lift **250kg at 2.5 metres, 400kg at 1.6 metres and 700kg at 0.9 metres**. The boom rises to 2.4 metres above the surface of the tray and lowers to approximately 50 cm below the tray. A complete Lindsell Hoist™ includes the base, boom, power cable, radio remote, adjustable support leg, bolts, nuts and diagram form safety instructions. The Australian made hydraulic cylinders are a standard type ensuring easy service no matter what part of Australia you are located in.

STANDARD SAFETY FEATURES

- Built-in relief valve to avoid overloading.
- Velocity-fuse (hose burst) for hydraulic cylinder. Designed by Lindsell Hoists™.
- Flow control valve enabling the operator to adjust the speed at which the boom is lowered and raised.

TWO WAY RATCHET LOCKING SLEW BOOM DESIGNED & REGISTERED TO LINDSELL HOISTS™

This enables the operator to work the load without the risk of backward slew towards the operator. Both directions are lockable making the Lindsell Hoist one of the safest manual handling hoists available. All pins are hardened and CNC machined to give optimum performance in all weather conditions.

NEW PRODUCTS FOR LINDSELL HOISTS™

Lindsell Hoist™ Model JRT Full Hydraulic Slew, Hydraulic Extension Boom and Hydraulic Lift Up to 1 tonne

Lindsell Floor Cranes – Made to your specifications, solid, rubber, pneumatic wheels to ASA 1418 standards

Lindsell Hoists™ Radio Remote Control

- All Lindsell Hoists are now available with Radio Remote control.
- Safer work environment i.e. no cords to trip over. 20 metre range
- Easy press pad function LED light and synchronised unit
- Automatic off when not used. Easy read pad key functions
- Made and assembled by Lindsell Hoists Two Year Warranty

Should you require any further information, or a 3 minute Video/CD on the “Lindsell Hoist™” contact our office. We may be able to place you in contact with someone in your area who already has a Lindsell Hoist, as there are thousands throughout Australia and Pacific regions.

Yours sincerely

Murray Lindsell Turner
 Managing Director

RETAIL PRICE LIST NOT INCLUDING FRIGHT CHARGES P.O.A

Ratchet Locking Slew (RLP) is Exclusive to Lindsell Hoists™

1. Model L-12RLP or L-24RLP Ratchet Locking Slew



2 Button Radio Remote Control.....\$2,790.00 Add 10% GST
Lift Capacity **700kg at 0.9 metres**
400kg at 1.6 metres
250kg at 2.5 metres (manual extension)
Reach Maximum 2.5 metres Boom
Height Above Tray 2.4 metres, Height Below Tray 50cms

2. Model L-12RLP3 or L-24RLP3 Ratchet Locking Slew & Hydraulic Extension

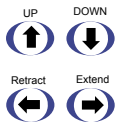

4 Button Radio Remote Control.....\$3,790.00 Add 10% GST
Lift Capacity **700kg at 0.9 metres**
400kg at 1.6 metres
250kg at 2.5 metres (Hydraulic 2" x36" Second Stage)
Third Stage Manual to 3.2 metres (Optional)

3. Model JRT 12/24v Full Hydraulic Slew

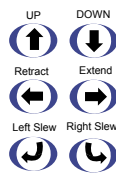

Six Button Radio Remote Control.....\$4,990.00 Add 10% GST
Lift Capacity **700kg at 0.9 metres**
400kg at 1.6 metres
250kg at 2.5 metres
Hydraulic Slew 300°
Hydraulic Extension 36 " Second Stage: Third Stage MANUAL (Optional)
Support Leg Manual

4. Model JRT 12/24v 1 TONNE Full Hydraulic Slew

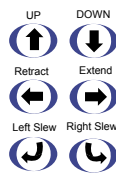

Six Button Radio Remote Control.....\$5,790.00 Add 10 % GST
Lift Capacity **1000kg at 0.9 metres**
500kg at 1.6 metres
300kg at 2.5 metres
150kg at 3.2 metres
Hydraulic Slew 300°
Includes 3rd stage manual boom

5. Lindsell Floor Crane

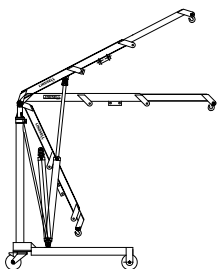

Model CMHP.....\$3,690.00 Add 10% GST
Lift Capacity **1000kg at 0.9 metres**
400kg at 1.6 metres
250kg at 2.5 metres

Contact Customer Service
For details such is flow control, manifold adaptor and specifications

6. Combined Lindsell Hoist™ and Tipper All models available

Model L-12HT or L24HT.....	\$4,990.00 Add 10% GST
Combined Lindsell Hoist RLP#3.....	\$5,980.00 Add 10% GST
Combined Lindsell Hoist JRT.....	\$6,480.00 Add 10% GST

7. Tipper Frame 1 Tonne Twin Cylinder

Model Tipper.....	\$2,990.00 Add 10% GST
Tipper Frame 1.2 Tonne Capacity Includes 2" x 16" Cylinders, Locking Clamp #3 Way Ball Valve & Hosing, Fittings	

8. Lindsell Hoist™ to suit existing Tipper**

Model L-RLP.....	\$2,440.00 Add 10% GST
Model RLP#3.....	\$3,490.00 Add 10% GST
Model JRT.....	\$4,690.00 Add 10% GST

9. Drum Sling Straight Lift 500 kg Ratchet Clamp

Model DR-2.....	\$160.00 Add 10% GST
-----------------	----------------------

10. Drum Sling Full Rotating Lift 250 kg

Model FTDR.....	\$346.00 Add 10% GST
-----------------	----------------------

11. Drum Grabs 500kg Triple Top clamp

Model TCDR.....	\$460.00 Add 10% GST
-----------------	----------------------

12. Round Slings 1 Tonne by 2 metres

Model SL.....	\$55.00 Add 10% GST
---------------	---------------------

13. Flat Slings (All sizes available by weight and length)

Model FL.....	\$55.00 Add 10% GST
---------------	---------------------

14. Radio Frequency Control (TO UPGRADE EXSITING LINDELL HOIST OR REPLACEMENT)

Model- L-12RLP or L-24RLP.....	\$300.00 Add 10% GST
Model- L-12RLP#3 and L-24RLP#3.....	\$350.00 Add 10% GST
Model- JRT.....	\$455.00 Add 10% GST

- All Radio Remotes are sold and serviced by Lindsell Hoists™
- Auto-Shut Down after 3 minutes when not used.
- Clear labels
- Battery Included
- Separately synchronized
- Up to 20 metres clearance operation
- Made in Australia

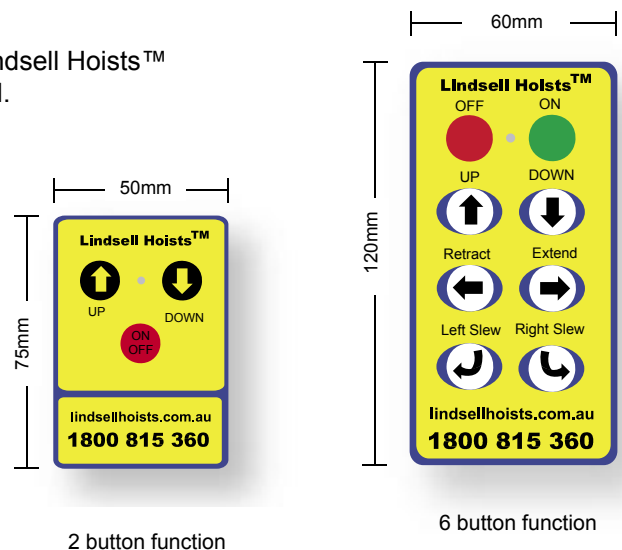

SPECIALIST LIFTING SLINGS

Please note we have a full range of specialist slings on request to suit all your lifting requirements. All made to Australian Standards or International Codes of Safety.

FREIGHT CHARGES ARE NOT INCLUDED IN RETAIL PRICES

These are subject to the point of delivery and are quoted and confirmed prior to delivery. We endeavor to use local carrier services throughout Australia and Pacific Regions.

Note: Prices are subject to change without notice

* Denotes 10 Year warranty on Lindsell Hoists Frame Only. Please note not including hydraulics and fittings.

** Denotes that hydraulic flow rates are to be specified prior to installation and approved by Lindsell Hoists™

POSTAL ADDRESS:

Lindsell Hoists™
Locked Bag 1
Point Leo
Victoria 3916

CONTENTS OF LINDELL HOISTS™

Each unit has installation drawings and instructions on safely operating. Please read them carefully. The Lindsell Hoist is designed to have all the necessary components to install the unit on any vehicle tray. If reinforcing of the tray is necessary, recommendations are shown, but materials are not provided. All Lindsell Hoists™ has a Two Year Comprehensive Warranty on all components.

Also available are the Lindsell Floor Crane and Materials Handling Range – Freecall 1800 815 360

Ask for the Free Lindsell Hoists CD to be posted or email format.



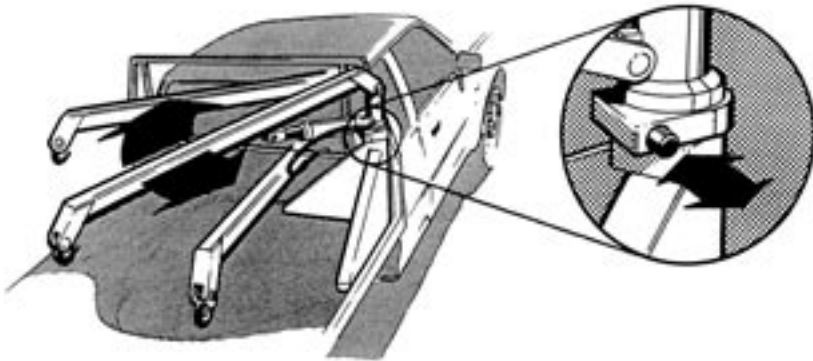

WORLDS FIRST RATCHET LOCKING SLEW

TELESCOPIC BOOM
2.5 METRE EXTENSION BOOM.
CLOSED LENGTH 1.6 METRES

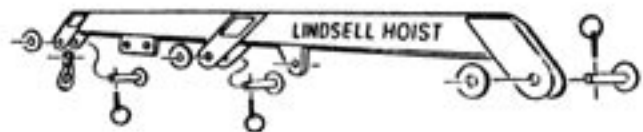

SHOWN HERE IS A TYPICAL INSTALLATION
MODEL L-12RLP LINDELL HOIST

NOTE : ALUMINIUM TRAYS WILL NEED
REINFORCING MATERIAL. THIS IS NOT
SUPPLIED. THIS MAY ALSO APPLY FOR STEEL

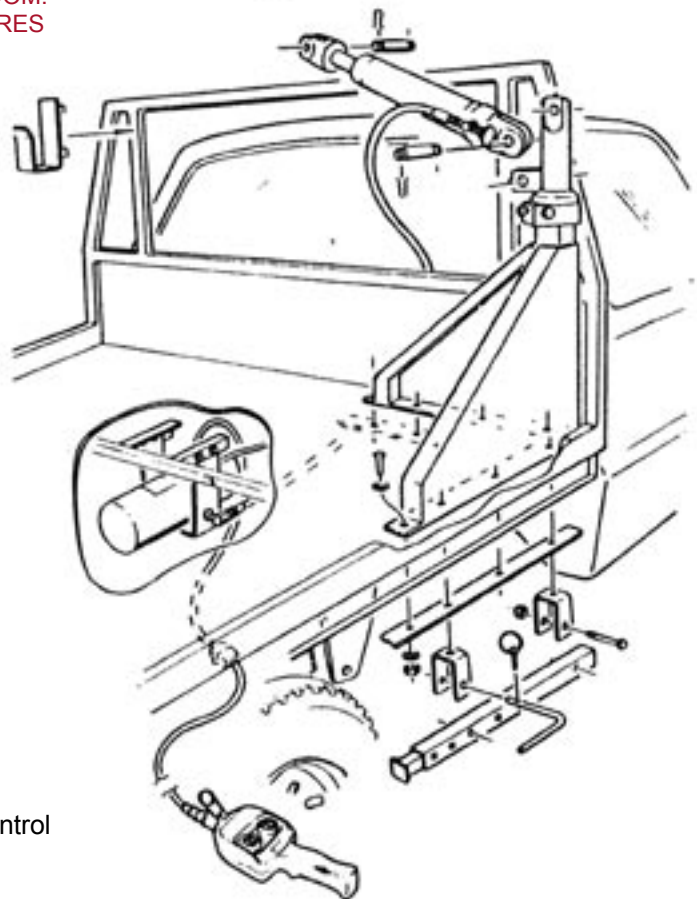

ALL LINDELL HOISTS™

- Bolts on to deck – timber , aluminum and steel
- The First Australian Designed Ratchet Slew Control
- Option of Hydraulic Slew Control
- Radio Remote Control
- Support Leg Standard
- Fits to existing hydraulics
- Easy to follow instructions
- 10 Year Warranty * Full Service Plan and Maintenance Program with every unit
- Over 5000 Clients Australian Wide

D.I.Y or Local Dealer Installation

LINDESELL HOISTS™ MATERIALS HANDLING EQUIPMENT

- Built by Lindsell Hoists™
- Built to your lifting needs
- Built to ASA 1418
- All terrain wheels available
- 12V , 240 V or Hand-pump
- Proudly Made in Australia

HYDRAULIC TIPPER KIT

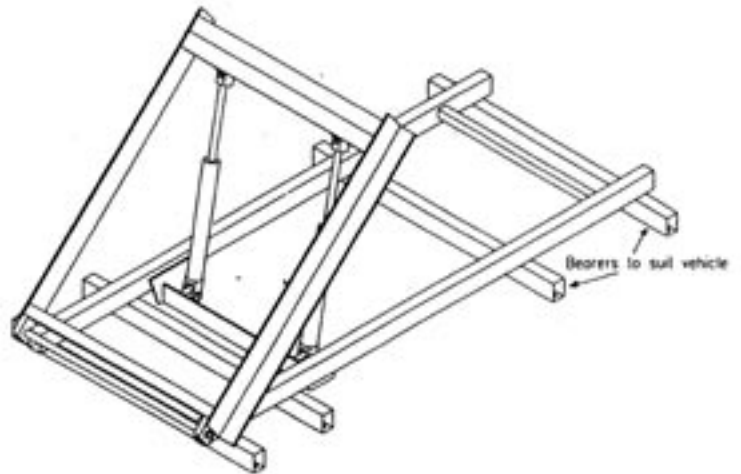

MULTISTAGE CYLINDER

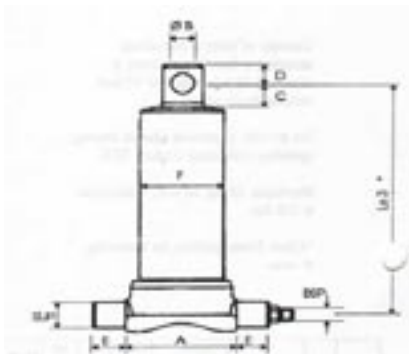

- Independent frame supplied
- Do it yourself installation
- Easy fit, detachable hydraulic hose and fittings supplied
- Fits all types of trays
- Twin cylinder for safer 1.2 tonne lifting
- 12 or 24 volt hydraulic power unit supplied
- Locking pins to secure tray to chassis
- Transfers easily for updated vehicles
- Delivered Australian wide
- Guaranteed 1 year warranty

HYDRAULIC FLOOR CRANE

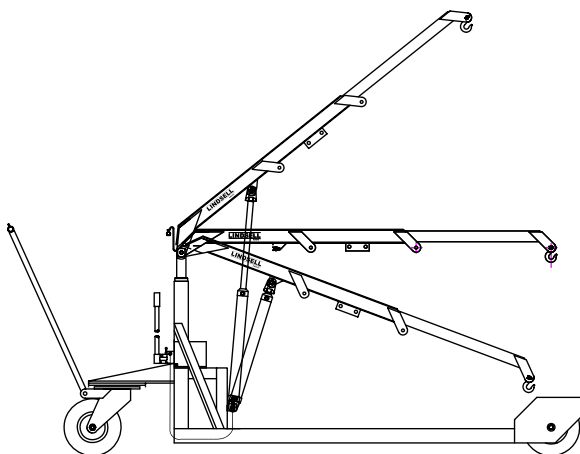

1 TONNE JRT MODEL

